

901649D-2

PRICE: \$.75

DIAGNOSTIC PROGRAM MANUAL

**SIGMA 5 THROUGH 9
DIAGNOSTIC PROGRAM
MONITOR (DPM)**

PROGRAM NO. 705682D02

**Specifications and procedures contained herein
are subject to change without notice.**

February 1974

This publication supersedes 901649D
dated December 1971

Prepared by
Sales & Service Education & Performance

XEROX

701 So. Aviation Blvd., El Segundo, Calif. 90245, 213 679-4511

SUBJECT MODEL -- This program is used as the operating monitor program for DPM peripheral test programs. Refer to the individual test programs for further information.

REQUIRED EQUIPMENT -- Minimum Memory Size: 16K; Input Device: Card Reader, Paper Tape Reader or Magnetic Tape Input; Output Device: Keyboard Printer or Line Printer. The remote facility is available in systems with more than 16K of memory.

PROGRAM LOADING INSTRUCTIONS

From Magnetic Tape Library

- Mount tape on unit 0 (without write-ring) and set its address on the control panel
- Reset all sense switches
 - Exception: Set sense switch 1 if the upper core protection is desired
- Execute a LOAD from the control panel:
 1. If sense switch 1 is reset, the loader is loaded to the upper end of memory.
 2. If sense switch 1 is set, the following occurs:
 - a. If the keyboard printer is not on IOP 0, device address 1, the program will come to a wait. Enter the correct address into register 2 and clear the wait.
 - b. If the keyboard printer is at the standard address or the correct address has been entered, the following three messages will be printed: (Reset sense switch 1 once printing has begun)
 - RELOCATION BIAS FOR RESIDENT LOADER IN HEX; Type in the hexadecimal memory address of the first location the resident loader is to occupy in memory followed by a carriage return. Minimum address is 400 and the maximum address is IFE00 or maximum memory size less 200.
 - RELOCATION BIAS FOR DIAGNOSTIC PROGRAM IN HEX; DPM programs may not be relocated, therefore type in only a carriage return.
 - ALTERNATE INPUT DEVICE ADDRESS; To continue loading, type in only a carriage return.
 - Loading will continue following the third entry

A message giving the tape library title and revision letter should be typed out from the keyboard

 - Type in the program name desired and a N/L
 1. If a listing of all programs on tape is desired, type: !LIST, ADR, N/L N/L where ADR = output device address in hex. Default is to the keyboard printer.
 2. If the full name cannot be remembered, type in the partial name and a N/L. Complete the partial name by selecting the desired name from the suggested names typed out by program.
 - To make a copy of the MTL, mount MTL on unit 0 and execute a LOAD. Mount scratch tape on unit 1 and make ready. Type: !COPY. The MTL tape will be copied to the scratch tape and verified.

From Card Deck (same for Paper Tape)

- Place card deck in Card Reader and set its address on the control panel
- Reset all sense switches
 - Exceptions: Set sense switch 1 if the upper core protection is desired or sense switch 2 if register control

is desired by the keyboard printer (ASR DPM) test, program no. 705651

- Execute a LOAD from the control panel:
 1. If sense switch 1 is reset, no wait will occur unless sense switch 2 is set (see 3.)
 2. If sense switch 1 is set, the following occurs:
 - a. If the keyboard printer is not on IOP 0, device address 1, the program will come to a wait. Enter the correct address into register 2 and clear the wait.
 - b. If the keyboard printer is at the standard address or the correct address has been entered, the following three messages will be printed: (Reset sense switch 1 once printing has begun)
 - RELOCATION BIAS FOR RESIDENT LOADER IN HEX; Type in the hexadecimal memory address of the first location the resident loader is to occupy in memory, followed by a carriage return. Minimum address is 400 and the maximum address is IFE00 or maximum memory size less 200.
 - RELOCATION BIAS FOR DIAGNOSTIC PROGRAM IN HEX; DPM programs may not be relocated, therefore type in only a carriage return.
 - ALTERNATE INPUT DEVICE ADDRESS; To continue loading, type in only a carriage return.
 - Loading will continue following the third entry
 3. If sense switch 2 is set, the program comes to a wait:
 - Clear the wait, the program will come to a second wait
 - Enter X'FFFFFFF' into register 0
 - Reset sense switch 2
 - Clear the wait
 - The test program is automatically loaded (without requiring a "LOAD" directive) and comes to a wait.
- The KSR/ASR program will operate in register control mode.

Exceptions: Sense switch 2 option was used or the keyboard is not on IOP 0, device address 001.

1. If sense switch 2 option was used, "LOAD" directive will automatically be performed
2. If keyboard is not address 001, the program will come to a wait:
 - Enter IOP and device address of the keyboard into register 2, i.e. X'105'
 - Clear the wait
 - "!" should be typed on keyboard
- Type in "LOAD" and a "Space Character" if sense switch 2 option was not used. A message giving the program name and revision letter should be typed out

DIRECTIVES -directives are entered after a "!" is typed out

Name	Format	Parameter			
		ID	Definition	Value Range	Standard Value (default)
Monitor Directives					
Message Output Device	MOD, A, IXX	A	Device type	TY (KSR/ASR) LP (Line Printer)	TY
		I	IOP number	0 ~ 1F	0
		XX	Device controller address	00 ~ 7F	01
Message Input Device	MID, A, IXX	A	Device type	TY (KSR/ASR) CR (Card Reader) PR (Paper Tape Reader)	TY
		I	IOP number	0 ~ 1F	0
		XX	Device controller address	00 ~ 7F	01
Dump Memory	DMP, H1, H2 [,C]	H1	Starting address	0 ~ FFFFF	0
		H2	Ending address	0 ~ FFFFF	
		C	Relative address flag (displacement from the starting address)	C ≠ 0	
Dump Memory on ASR/KSR	TDMP, H1, H2 [,C]	H1	Starting address	0 ~ FFFFF	0
		H2	Ending address	0 ~ FFFFF	
		C	Relative address flag (displacement from the starting address)	C ≠ 0	
Alter Memory	ALT, H1, X1 [,...,XN]	H1	Memory address Values to be inserted into memory starting from H1	0 ~ FFFFF	
		X1		}	
		XN			
Load Program (from object deck)	LOAD, [H1]	H1	Load device address	0 ~ 1FFF	Initial loading device

(Continued)

DIRECTIVES (Continued)

Name	Format	Parameter			
		ID	Definition	Value Range	Standard Value (default)
Monitor Directives (Available Only If Memory Size > 16K).					
These directives simulate PCP control and provide remote troubleshooting facilities.					
Turn On Pseudo Sense Switches	SON [,D1, D2, D3, D4]	D1 D2 D3 D4	Sense switch number Sense switch number Sense switch number Sense switch number	1 ~ 4 1 ~ 4 1 ~ 4 1 ~ 4	D1 thru D4 =0, display pseudo sense switches
Turn Off Pseudo Sense Switches	SOFF [,D1, D2, D3, D4]	D1 D2 D3 D4	Sense switch number Sense switch number Sense switch number Sense switch number	1 ~ 4 1 ~ 4 1 ~ 4 1 ~ 4	D1 thru D4 =0, display pseudo sense switches
Use Real Sense Switches	SSWC				
Simulate PCP Reset	RES				
Set Address Stop	STOP [,H1]	H1	Stop address	0 ~ FFFF	D1 = 0; Remove address stop
Continue with next instruction after program wait or address stop (from stop directive)	GO (continue with next location after wait) GO1 (continue with next location +1 after wait)				
Start Program at Location n.	BR, H1	H1	Branch address	0 ~ FFFF	Note: Registers or flags may not be set up correctly.
Allow Remote User to Log On	LOG, A, H2, H3	A H2 H3	4-character password COC address DIO address of COC	Alpha/num characters 0 ~ 1F7F 0 ~ F	0
Swap Control Between Controller and Observer	SWAP				
Disconnect Remote Users	ROFF				
Load Another Program from MTL	BOOT [,H1]	H1	Load device address	0 ~ 1FFF	Initial loading device

DIRECTIVES (Continued)

Name	Format	Parameter			
		ID	Definition	Value Range	Standard Value (default)
Program Directives - Environmental Directives					
System Environment	SYST, D1, D2, H3, H4, ..., HN	D1 D2 H3 H4 . . . HN	Device or controller model number	The 'SYST directive interpretation and value ranges are supplied by the program loaded by the 'LOAD' directive. Refer to the applicable diagnostic program reference manual. Also, the diagnostic program will generally print its 'SYST' format following the 'LOAD' operation.	
Program Directives - Testing Directives					
Test Directives (used to test a device or to modify test data)	Determined by Diagnostic Program		Supplied by the Diagnostic Program. Refer to the applicable Diagnostic Program Reference Manual.		

Note: Parameter of any directive beginning with a D means decimal, with an H means hexadecimal.

LOADER ERROR MESSAGES

Error Message	Description of Error
Sequence Error Job Aborted	The last record read was out of sequence (if reading cards, the deck may be missing a card) and loading has been aborted
Checksum Error Job Aborted	The last record read had a checksum error (the input media may be damaged) and loading has been aborted
Dev Not Redy	The input device failed to come 'READY' following the last read operation and loading has been aborted
Illegal Load ITM	The last record read contained an illegal load item type and loading has been aborted

1. If any loader error message is printed, loading has been aborted
2. Retry entire loading procedure:
 - a. If identical error occurs, obtain a new copy of the program
 - b. If loading still fails, check input device for correct operation

MONITOR ERROR MESSAGES

All monitor error messages are output to the keyboard, KSR, and have the following format:

MONITOR ERROR XXXX where XXXX is a four-digit number. 1801

Diagnostic program does not show the model number specified in a SYST directive that is executed while diagnostic program is loaded

The four-digit error numbers have the following interpretation:

ERROR NO. DESCRIPTION OF ERROR

0700 Illegal address (ALT directive, DMP directive, message print routine) 1802

Context data block in diagnostic program is not long enough

1000 Illegal device mnemonic, parameter A1, MOD directive 1804

Context data table in diagnostic program shows zero model numbers to which a context data block applies

1100 Illegal device mnemonic, parameter A1, MID directive 2201

SIO yielded IOP halt

1200 Illegal character in a hexadecimal parameter 2202

SIO yielded incorrect length indication

1201 Illegal character in a decimal parameter 2203

SIO yielded IOP memory error indication

1202 No termination or continuation character in first 72 characters of a record containing a directive input from a device other than the keyboard/printer 2204

SIO yielded memory address error indication

1203 First character of a continuation line is not an exclamation 2205

SIO yielded transmission memory error indication

1301 First character of a record is not an exclamation 2206

SIO yielded transmission data error

1302 Illegal directive 2301

SIO not accepted after maximum delay

1303 More parameters indicated for a directive than authorized 2302

I O address not recognized

1800 No parameters with SYST directive 2303

I/O interrupt fails to reset

Device not operational

Controller not operational

SIO rejected after operational status byte obtained

Manual mode

START PROCEDURE

1. Sense Switch Options

Sense Switch	Position	Function
1	Reset	Continuous operation, no looping
1	Set	Loop on failing test or selected test if SSW3 is set
2	-	Not used *
3	Reset	Wait on error or successful completion of tests. (Clearing the wait causes looping on the error or selected test. PCP instruction address increment before clearing the wait continues the program without looping.)
3	Set	No wait after error or successful completion of test. See SSW1 for looping
4	Reset	Print all message(s)
4	Set	No message printout except from the monitor

*Note: Sense switch 2 may be used during the loading of the Diagnostic Program Monitor, see Program Loading Instructions.

2. Monitor Directive Options - Desired Monitor Directive(s) entered
3. Environmental Directives - SYST directive is entered for test environment (Diagnostic Program Dependent)
4. Test Strategy Selection (Diagnostic Program Dependent)
5. Repeat 1, 2 and 4 when the program terminates. Repeat 3 only if system environment is to be changed

TERMINATION INDICATION

1. Completion of a directive - Control returns to the message input device or loops on an instruction sequence
2. Error indication - Error message printout or looping on an instruction sequence
3. PCP interrupt - Control returns to the message input device and the current operation is aborted
4. Watchdog timer trap - WAIT without message (if no jumper for I/O reset)
 - Looping with message (if no jumper is connected, Sigma 5: 4C17 to 6C15, Sigma 7: 27G21 to Ground)
5. Other traps or interrupts - The following type-out will occur:

```
TRAP/INTER = XX   TCC = YYYY   REGSAVE = AAAAAAAA
PSW1 = TTTTTTTT  PSW2 = RRRRRRRR
```

 where: XX Denotes the trap or interrupt location
 YYYY Denotes the trap condition codes
 AAAAAAAA Denotes the location in memory where the register contents at the time of the trap or interrupt are stored
 TTTTTTTT and RRRRRRRR are the contents of the Program Status Doubleword saved by the LPSD instruction executed as a result of the Trap or Interrupt
 - a. Memory Fault Trap or Interrupt only - The program will Type-Out: (Sigma 8 and 9 only)

```
MSWO = WWWWWW   MSW1 = EEEEE   MSW2 = RRRRRR
```

 Giving the status of the faulted memory
 - b. Processor Fault Interrupt only - The program will type-out: (Sigma 8 and 9 only)

```
PROC. NO.  SS  F/STAT = C
```

 Giving the faulted processor address and the fault status

RESTART PROCEDURE

1. Perform applicable steps under Start Procedure
2. Depress System or CPU reset switches and return the system to a RUN condition. Control returns to the message input device and the current operation (if any) is aborted
3. PCP Interrupt - Control returns to the message input device and the current operation (if any) is aborted
4. If program fails to restart correctly, reload the program

REMOTE FACILITY

Control

To allow a remote user to log on, the controller must use the directive !LOG. The parameters contain the password, the COC address, and the DIO Address (0 - F) e.g., !LOG,DIAG,5,1

Upon receipt of this directive, the COC will be activated and all lines scanned for input. If (and when) a connect signal is received, a log in message is sent to that line. The valid reply to the log in message is password. If the password is received, that teletype becomes the observer and all other lines are ignored. The controller is informed when the user has logged on.

To transfer control from the controller to the observer, the controller must use the directive !SWAP. There are no parameters for the directive.

To disconnect the COC and the remote user, the local user when he is the controller can issue the directive !ROFF. No parameters are required.

If the program detects that the remote user is "lost" due to some malfunction, the program continues with the local user as the controller even if the remote user was controller; and the COC is set up ready to reconnect the remote user equivalent to its state following a !LOG directive.

If the local ASR/KSR is "lost" due to a malfunction, the program will "WAIT".

Directive Mode

In directive mode the controller is issuing a directive to the system. The observer obtains a copy of the directive but cannot communicate with the system or the controller.

The system is in directive mode when:

- a. The DPM has typed out a ! and is awaiting input.
- b. The system was running and the controller types in a !.
- c. The local user, if controller, stops output with break key.
- d. The remote user, if controller, stops output with the ! or escape key.

The system is not running when in directive mode.

If the local user is the controller, the local ASR/KSR is in input mode and characters input are passed to the system for use as the directive and any associated parameters. The input is copied to the remote user. Input from the remote user is ignored except as outlined under Message Mode.

If the remote user is the controller, characters from this device are used as the directive and its associated parameters. All characters input are echoed to the device and copied to the local ASR/KSR. Input from the remote user is ignored except as outlined under Message Mode.

Directives are terminated by any character other than:
A - Z 0 - 9, ; - (!)

Message Mode

In message mode, the two users can communicate with each other via their respective teletype devices. The characters are passed from one to the other and do not effect the system operation.

The system is in message mode when:

- a. The program is running.
- b. The system entered directive mode and the controller has not input any characters.
- c. The system was in directive mode and the controller types in a (. This condition continues until the controller types in a) or a !.

Characters from the remote user are echoed to the device and copied to the local ASR/KSR.

Input from the local ASR/KSR is copied to the remote user. The local ASR/KSR is input mode at all times unless characters need to be output to it.

If the local user is the controller and the device is not in input mode because of output the user can obtain control by the procedure described under System Output.

System Output

System output is sent to both the local ASR/KSR and the remote user.

Input other than a !, escape, or NUL character from the remote user is ignored.

Output can be stopped by the controller in two different ways.

- a. Output of a single message line can be terminated by the controller hitting the NUL key if he is the remote user or depressing the break key from .1 to .9 seconds if he is the local user.
- b. Output can be terminated and the DPM forced into directive mode by the controller hitting the ! or escape key if he is the remote user or depressing the break key for more than 1 second if he is the local user.

PCP FACILITY

Sense Switches

Real sense switches - these are the hardware sense switches on the PCP which are switched manually and their position can be found by a read direct instruction.

Pseudo sense switches - these are four positions in a defined memory location. If the bit is a one, the switch is on. Directives are available to change the settings.

After loading, if no information is received from the magnetic tape library control program about pseudo sense switches, and until (if ever) a directive is used to adjust the pseudo sense switches, the real sense switches control the program.

Following a directive to set/reset one or more of the pseudo sense switches, the pseudo sense switches control the program. A directive allows the system to switch back to using the real sense switches.

If the magnetic tape library control program informs the DPM that the pseudo sense switches are in use, then the settings will be used as received and pseudo switches will control the program until the !SSWC (see below) directive is used.

The pseudo sense switch directives are:

For turning switches on:
!SON, n₁n₂n₃n₄

For turning switches off:
!SOFF, n₁n₂n₃n₄

Any number of parameters up to a maximum of four can be used and the values must be in the range 1 to 4.

e.g., !SON,3 Turns on pseudo sense switch 3
 !SOFF,4,1 Turns off pseudo sense switch 4 and 1.

If the first pseudo sense switch directive used following the use of the real sense switches does not change all four switches, the state of the others are copied from the corresponding real switches.

Following a pseudo sense switch directive the state of all the switches are shown, e.g., assume that real switches are 0101, and this is the first pseudo sense switch directive.

```
!SON,1
!!SW1234
!! 1101
```

If no parameters are given, no switches are set or reset but a printout of the current positions occurs.

A type-in of either:
!SON or !SOFF
results in a type-out of:
!!SW1234
!! 0101

To revert to the use of real sense switches the directive !SSWC is used, no parameters are required.

WAIT Instructions

Because WAIT instructions cannot be observed or cleared from a remote location they will be eliminated as far as possible from the system.

A WAIT instruction in the last program is replaced by a call to a subroutine in the DPM. The routine will type a message and then give the user control, e.g.,

```
BAL,15               :WAIT               (address via MLT+43)
DATA                MESS1             ADDRESS OF MESSAGE
```

The controller can use the !ALT directive to adjust any locations required and use the !GO or !GO1 directives described below to continue the program.

The only situations which still require PCP control are:

1. If after loading, an ASR/KSR cannot be found - a WAIT is performed and the user puts a valid ASR/KSR address in register 2.
2. If I/O to the ASR/KSR cannot be performed the program will WAIT.
3. If a manual reset is required after a trap - the program hangs.
4. If the local user depressed control panel interrupt switch to gain control of the program.

PCP FACILITY (Continued)Address Stop Function

A directive is implemented to simulate the address stop feature of the PCP.

To set an address stop the controller uses the !STOP directive. The parameter is the address at which the program should stop, e.g.,

```
!STOP,2FE.
```

This directive will cause an XPSD to be placed into the address specified. If the XPSD is executed, a type out of the saved PSW1, PSW2 and the address of a stack containing the saved PSW1, PSW2 and all the registers (0-15) will occur and the user obtains control. The PCP will not reflect the saved machine state.

The user may change the saved PSW1, PSW2 and registers by use of the !ALT directive. The layout of the stack will be:

```
ADDRESS PRINTED      REGISTER 0
                     REGISTER 1
                     .
                     .
                     .
                     REGISTER 15
                     PSW1
                     PSW2
```

and the address of register zero will be on a 16 word boundary.

The controller can continue the program with the replaced instruction, or with the new environment if he has changed any of the saved values, by using the !GO directive.

A second !STOP directive with a new address causes the initial instruction to be replaced at its correct address and the XPSD to replace the instruction at the address specified.

A !STOP directive without an address causes the XPSD to be removed and the location replaced with its valid instruction; i.e., the address stop is removed.

Reset Function

A directive is implemented to simulate a reset from the PCP. A reset from PCP is performed by:

- a. Hitting the interrupt button.
- b. Putting the CPU into IDLE, hitting reset, and putting CPU to RUN.

This function can be simulated by the controller using the !RES directive. No parameters are required.

A reset does not disconnect the remote user. In all cases the DPM will remember if there was a remote user. Control after a reset will revert to the controller.

Continue Function

Two directives are implemented to work in conjunction with the !STOP directive, the programmed WAIT instruction and to simulate the RUN/IDLE switch on the PCP. When the program has stopped running because:

- a. It arrived at the simulated stop address.
- b. It arrived at the :WAIT subroutine.
- c. The controller typed in an ! character or stopped output via break key.

The program can be continued correctly at the next "logical" instruction by using the !GO directive. No parameters are required. The next "logical" instruction is defined in the three cases above as:

- a. The instruction which was replaced by the XPSD, or the new environment if the user altered PSW1, PSW2 and/or any of the saved registers.
- b. The instruction which presently follows the WAIT instruction.
- c. The next instruction in the main line code which would have been executed if the system had not switched to directive mode. There will be a loss of output if break key stopped output. A continuation of the test (with GO directive) may lead to error printouts.

At present following a WAIT associated with the sense switch routine the user either clears the WAIT and continues at the next instruction, or he increases the Instruction Register by 1 and then continues. The !GO directive simulates the former action and another new directive !GO1 will simulate the latter action.

PCP FACILITY (Continued)

Between the time the program stops running and the issuance of the !GO or !GO1 directives the user may issue any of the following directives:

!LOG, !SON, !SOFF, !SSWC, !STOP, !MID, !MOD, !DMP, !ALT, !TDMP

If any other directives are issued the DPM will "forget" the "place to go", e.g.,

```

SYSTEM RUNNING
!DMP          (DPM remembers next logical instruction)
!ALT
!SON
!GO
System restart at next logical instruction
SYSTEM RUNNING
!SON          (DPM remembers next logical instruction)
!TST1
System restarts with Test 1 and forgets the logical instruction address.

```

Branch Function

A new directive is implemented to allow the controller to branch to any location he requires. The directive requires one parameter:

!BR,2FE.

The directive is intended to allow the user to depart from the normal diagnostic program procedure. Having taken the branch there is no guarantee that the program will perform according to the specification. The directive must be used with caution.

COMMAND DOUBLEWORD FORMAT

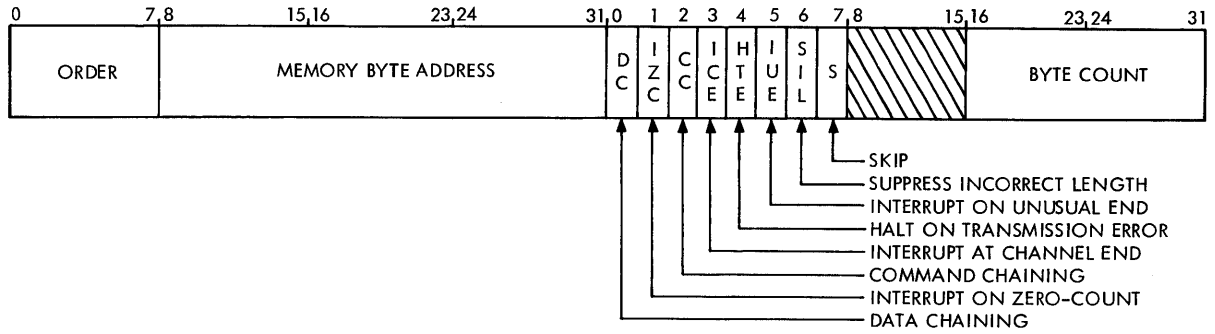

INPUT/OUTPUT INSTRUCTIONS

I/O ADDRESS

I/O STATUS RESPONSE

SIO, HIO, TIO, AND TDV

Multiunit device controllers (bit 24 is 1)

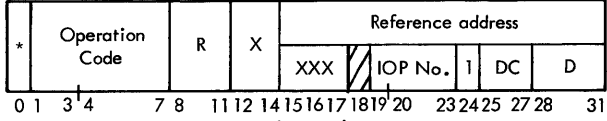

Sigma 8/9 systems only
 000 = HIO
 001 = RIO
 010 = POLP
 011 = POLR

Word into register R

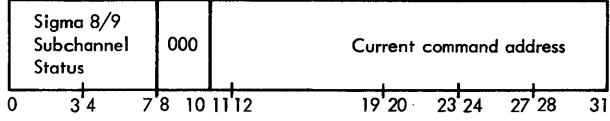

Word into register Rul

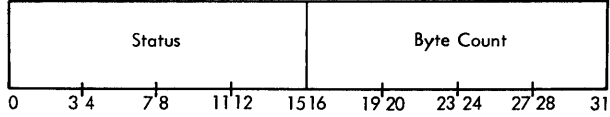

AIO

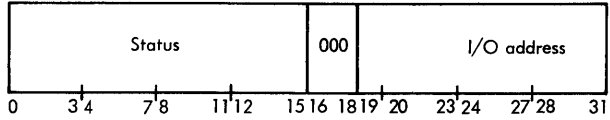
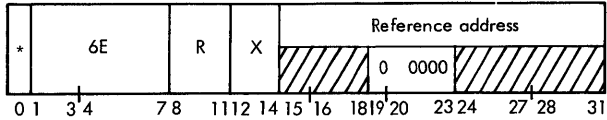

GENERAL CONDITION CODES

Note: These condition codes apply to most devices but they may differ. Refer to the individual device reference manual for correct condition code.

The condition code settings are:

1 2 3* 4 Result of SIO

- 0 0 - - I/O address recognized and SIO accepted
- 0 1 - - I/O address recognized but SIO not accepted
- 1 0 - - device controller is attached to a "busy" selector IOP or Sigma 8/9 MIOP operating in Burst Mode
- 1 1 - - I/O address not recognized

1 2 3* 4 Result of TIO

- 0 0 - - I/O address recognized and acceptable SIO is currently possible
- 0 1 - - I/O address recognized but acceptable SIO is not currently possible
- 1 0 - - device controller is attached to "busy" selector IOP or Sigma 8/9 MIOP operating in Burst Mode
- 1 1 - - I/O address not recognized

1 2 3* 4 Result of HIO

- 0 0 - - I/O address recognized and device controller is not "busy"
- 0 1 - - I/O address recognized but device controller was "busy" at the time of the halt
- 1 1 - - I/O address not recognized

1 2 3 4 Result of RIO (Sigma 8/9 only)

- 0 0 - - I/O address recognized
- 1 1 - - I/O address not recognized

1 2 3 4 Result of POLP or POLR (Sigma 8/9 only)

- 0 0 - - processor fault interrupt not pending
- 0 1 - - processor fault interrupt pending
- 1 1 - - processor address not recognized

1 2 3* 4 Result of TDV

- 0 0 - - I/O address recognized
- 0 1 - - I/O address recognized and device-dependent condition is present
- 1 0 - - device controller is attached to "busy" selector IOP or Sigma 8/9 MIOP operating in Burst Mode
- 1 1 - - I/O address not recognized

1 2 3* 4 Result of AIO

- 0 0 - - normal interrupt recognition
- 0 1 - - previous operations ended with unusual end or transmission error
- 1 0 - - AIO is accepted
- 1 1 - - no interrupt recognition

*On Sigma 8/9 systems only

CC 3 = 0 Status information in general registers is correct

CC 3 = 1 Status information in general registers is incorrect

STATUS BITS FOR I/O INSTRUCTIONS

Position and State in Register Ru1

Device Status Byte				Operational Status Byte				Significance for SIO, HIO, and TIO		Significance for TDV							
0	1	2	3	4	5	6	7	8	9	10	11	12	13	14	15		
1	-	-	-	-	-	-	-	-	-	-	-	-	-	-	-	Dev Interrupt Pending	*
-	0	0	-	-	-	-	-	-	-	-	-	-	-	-	-	Dev Ready	*
-	0	1	-	-	-	-	-	-	-	-	-	-	-	-	-	Dev Not Oper	*
-	1	0	-	-	-	-	-	-	-	-	-	-	-	-	-	Dev Unavailable	*
-	1	1	-	-	-	-	-	-	-	-	-	-	-	-	-	Dev Busy	*
-	-	-	0	-	-	-	-	-	-	-	-	-	-	-	-	Dev Manual	Unique to the device and the device cntr
-	-	-	1	-	-	-	-	-	-	-	-	-	-	-	-	Dev Automatic	*
-	-	-	-	1	-	-	-	-	-	-	-	-	-	-	-	Dev Unusual End	*
-	-	-	-	-	0	0	-	-	-	-	-	-	-	-	-	Dev Cntr Ready	*
-	-	-	-	-	0	1	-	-	-	-	-	-	-	-	-	Dev Cntr Not Oper	*
-	-	-	-	-	1	0	-	-	-	-	-	-	-	-	-	Dev Cntr Unavail	*
-	-	-	-	-	1	1	-	-	-	-	-	-	-	-	-	Dev Cntr Busy	*
-	-	-	-	-	-	-	0	-	-	-	-	-	-	-	-	Unassigned	*
-	-	-	-	-	-	-	-	1	-	-	-	-	-	-	-	Incorrect Length	*
-	-	-	-	-	-	-	-	-	1	-	-	-	-	-	-	Trans Data Error	*
-	-	-	-	-	-	-	-	-	-	1	-	-	-	-	-	Trans Mem Error	Same as for SIO, HIO, TIO
-	-	-	-	-	-	-	-	-	-	-	1	-	-	-	-	Mem Addr Error	*
-	-	-	-	-	-	-	-	-	-	-	-	1	-	-	-	IOP Mem Error	*
-	-	-	-	-	-	-	-	-	-	-	-	-	1	-	-	IOP Contl Error	*
-	-	-	-	-	-	-	-	-	-	-	-	-	-	1	-	IOP Halt	*
-	-	-	-	-	-	-	-	-	-	-	-	-	-	-	1	Selector IOP Busy	*

Position and State in Register R

Device Status Byte				Operational Status Byte				Significance for AIO								
0	1	2	3	4	5	6	7	8	9	10	11	12	13	14	15	
1	-	-	-	-	-	-	-	-	-	-	-	-	-	-	-	*
-	1	-	-	-	-	-	-	-	-	-	-	-	-	-	-	*
-	-	1	-	-	-	-	-	-	-	-	-	-	-	-	-	*
-	-	-	1	-	-	-	-	-	-	-	-	-	-	-	-	*
-	-	-	-	1	-	-	-	-	-	-	-	-	-	-	-	Unique to the device and device controller
-	-	-	-	-	1	-	-	-	-	-	-	-	-	-	-	*
-	-	-	-	-	-	1	-	-	-	-	-	-	-	-	-	*
-	-	-	-	-	-	-	1	-	-	-	-	-	-	-	-	*
-	-	-	-	-	-	-	-	1	-	-	-	-	-	-	-	Incorrect Length
-	-	-	-	-	-	-	-	-	1	-	-	-	-	-	-	Trans Data Error
-	-	-	-	-	-	-	-	-	-	1	-	-	-	-	-	Zero BC Interrupt
-	-	-	-	-	-	-	-	-	-	-	1	-	-	-	-	Channel End Intrpt
-	-	-	-	-	-	-	-	-	-	-	-	1	-	-	-	Unusual End Intrpt
-	-	-	-	-	-	-	-	-	-	-	-	-	0	-	-	Unassigned
-	-	-	-	-	-	-	-	-	-	-	-	-	-	0	-	Unassigned
-	-	-	-	-	-	-	-	-	-	-	-	-	-	-	0	Unassigned

MONITOR LINK TABLE (MLT)

The MLT table allows the interfaced diagnostic program access to subroutines with the DPM and allows for data/information exchange between the DPM and the interfaced program.

Name	Definition	Memory Location	
		Program Location	Core Location
MLT	Absolute program recovery address	MLT+0	X'200'
MLT01	Parameter 1	MLT+1	X'201'
MLT02	Parameter 2	MLT+2	X'202'
MLT03	Parameter 3	MLT+3	X'203'
MLT04	Parameter 4	MLT+4	X'204'
MLT05	Unassigned	MLT+5	X'205'
MLT12		MLT+12	X'20C'
MLT13	Temporary ASR mode flag	MLT+13	X'20D'
MLT14	Unassigned	MLT+14	X'20E'
MLT15	'DMP' directive routine call location for interfaced programs	MLT+15	X'20F'
MLT16	DPM Reentry	MLT+16	X'210'
MLT17	Parameter status word	MLT+17	X'211'
MLT18	Unassigned	MLT+18	X'212'
MLT19	Binary coded decimal (BCD) to binary, conversion subroutine interface location	MLT+19	X'213'
MLT20	Directive return address - returns control to the DPM	MLT+20	X'214'
MLT21	Unassigned	MLT+21	X'215'
MLT22	Binary to EBCDIC conversion subroutine interface location	MLT+22	X'216'
MLT23	Decimal to EBCDIC conversion subroutine interface location	MLT+23	X'217'
MLT24	Hexadecimal to EBCDIC conversion subroutine interface location	MLT+24	X'218'
MLT25	One-byte input subroutine interface location	MLT+25	X'219'
MLT26	Current character counter for one-byte input routine	MLT+26	X'21A'
MLT27	Error report subroutine interface location	MLT+27	X'21B'
MLT28	Message print subroutine interface location	MLT+28	X'21C'
MLT29	Sense switch check subroutine interface location	MLT+29	X'21D'
MLT30	'WAIT' instruction, after I/O failure of 'MOD/MID' device	MLT+30	X'21E'
MLT31	Branch instruction - retry after I/O failure	MLT+31	X'21F'
MLT32	I/O address of current 'MOD' device (branch instruction)	MLT+32	X'220'
MLT33	I/O address of current 'MID' device	MLT+33	X'221'
MLT34	I/O address of initial loading device	MLT+34	X'222'
MLT35	Teletype print routine location	MLT+35	X'223'
MLT36	I/O address of default 'MOD/MID' device	MLT+36	X'224'
MLT37	Computer type code storage, 0 = Sigma 5/7, 9 = Sigma 8/9	MLT+37	X'225'
MLT38	Relocation bias of DPM program	MLT+38	X'226'
MLT39	Resident loader base address	MLT+39	X'227'

(Continued)

MONITOR LINK TABLE (MLT) (Continued)

Name	Definition	Memory Location	
		Program Location	Core Location
MLT40	Unassigned	MLT+40	X'228'
MLT41	Parameter error report subroutine interface location	MLT+41	X'229'
MLT42	Quick sense routine address	MLT+42	X'22A'
MLT43	Wait routine address	MLT+43	X'22B'
MLT44	DPM directive dictionary base address	MLT+44	X'22C'
MLT45	Length of DPM directive dictionary	MLT+45	X'22D'
MLT46	Address of last memory location	MLT+46	X'22E'
MLT47	Address of last memory location interfaced program may use	MLT+47	X'22F'
MLT48	Base address of 120 byte input buffer	MLT+48	X'230'
MLT49	Base address of 40 word parameter input buffer	MLT+49	X'231'
MLT50	'LOAD' directive memory location	MLT+50	X'232'
MLT51	Input routine address	MLT+51	X'233'
MLT52	Output routine address	MLT+52	X'234'
MLT53	Error routine address for DPM IO errors	MLT+53	X'235'
MLT54	Directive preprocessor	MLT+54	X'236'
MLT55	Unassigned	MLT+55	X'237'
.		.	.
.		.	.
.		.	.
MLT63		MLT+63	X'23F'

PROGRAM INTERFACE TABLE (PIT)

The PIT table is established by the user program at 'LOAD' time and provides the DPM with information describing the user diagnostic program.

Name	Definition	Memory Location	
		Program Location	Core Location
PIT	Unassigned	PIT+0	X'300'
PIT01	Address of the user program's title message	PIT+1	X'301'
PIT02	Address of the user program's directive dictionary	PIT+2	X'302'
PIT03	The count of the number of words in the user program's directive dictionary	PIT+3	X'303'
PIT04	Address of the user program's absolute recovery routine	PIT+4	X'304'
PIT05	Address of the user program's context description table	PIT+5	X'305'
PIT06	The count of the number of words in the user program's context description table	PIT+6	X'306'
PIT07	Unassigned	PIT+7	X'307'
PIT08	Address of the user program's initializer routine	PIT+8	X'308'
PIT09	Contains the last device model number input via 'SYST' directive transferred to a context data block	PIT+9	X'309'
PIT10	Specifies the number of the faulty parameter in a parameter error message	PIT+10	X'30A'
PIT11	The DPM stores a zero in PIT11 prior to branching to the user program's initialization routine. If this location is non zero upon returning to the DPM, the contents are assumed to be a message address and the message is printed	PIT+11	X'30B'
PIT12	The user program's RUN switch. This location must be non zero to execute a user directive. If zero when a user directive is called, the error message: 'ENTER SYST DIRECTIVE' is printed	PIT+12	X'30C'
PIT13	Unassigned	PIT+13	X'30D'
PIT14		PIT+14	X'30E'
PIT15	Address of the user program's trap and fault interrupt handling routine	PIT+15	X'30F'
PIT16	Unassigned	PIT+16	X'310'
.		.	.
.		.	.
.		.	.
PIT31		PIT+31	X'31F'

Fold

First Class
Permit No. 229
El Segundo,
California

BUSINESS REPLY MAIL

No postage stamp necessary if mailed in the United States

Postage will be paid by

Xerox Corporation
701 South Aviation Boulevard
El Segundo, California 90245

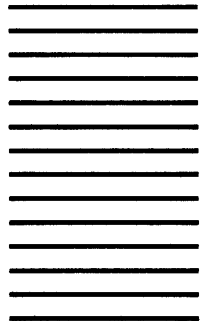

Attn: Field Engineering Publications

Fold